

AMERICAN RANGE

Chef Inspired, Professional Cooking Equipment

Culinary Series ARPFs FRYER FILTRATION

GAS TYPE: NATURAL LP

STANDARD FEATURES

- Portable Fryer Filtration System removes food particles and other solids from cooking oil.
- Fryer filter models available in 60 pound and 85 pound oil capacity.
- Provides significant savings in oil usage and great food quality results.
- Features a unitized Stainless Steel frame.
- Welded Stainless Steel pan with integrated handles for easy removal and cleaning.
- Rugged 1/3 HP UL and NSF approved motor and Gear pump designed for long life.
- 1/2" diameter Teflon lined, nylon braided hoses with UL and NSF approval.
- Unique nozzle design reducing splashing while providing spray to help wash walls of fryer during filtering.
- One year limited warranty, parts and labor.

OPTIONAL FEATURES

- Filter pads (30 per case).

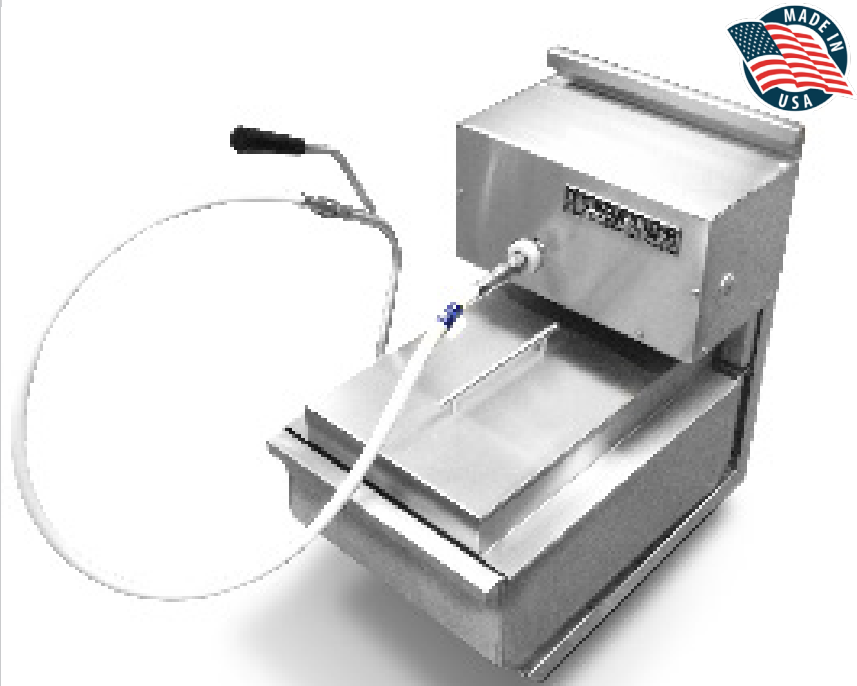

Model Shown ARPFS-35/50

Extending the life of cooking oil while delivering the best quality deep fried foods is the goal of every restaurant owner and chef. Periodically filtering your cooking oil to prolong its useful life using **The Culinary Series** by American Range, Portable Fryer Filtration System is a great step in the right direction. The Portable Fryer Filtration unit comes in two sizes - the ARPFS-35/50 with a 60 pound oil capacity and the ARPFS-85 with a 85 pound oil capacity. The unit rolls easily for use whenever it is needed and can easily be stored out of the way. The low profile allows the unit to roll directly under the drain valve outlet extension pipe on the fryer.

Returning customers and recurring revenue depends on high quality, consistent cooking results from your fryer. The American Range Portable Fryer Filtration System brings peace of mind, performance, and profit to your frying experiences!

Quality, dependability and customer satisfaction make American Range the **brand of choice among professional chefs and restaurateurs worldwide.**



Culinary Series

ARPFS FRYER FILTRATION

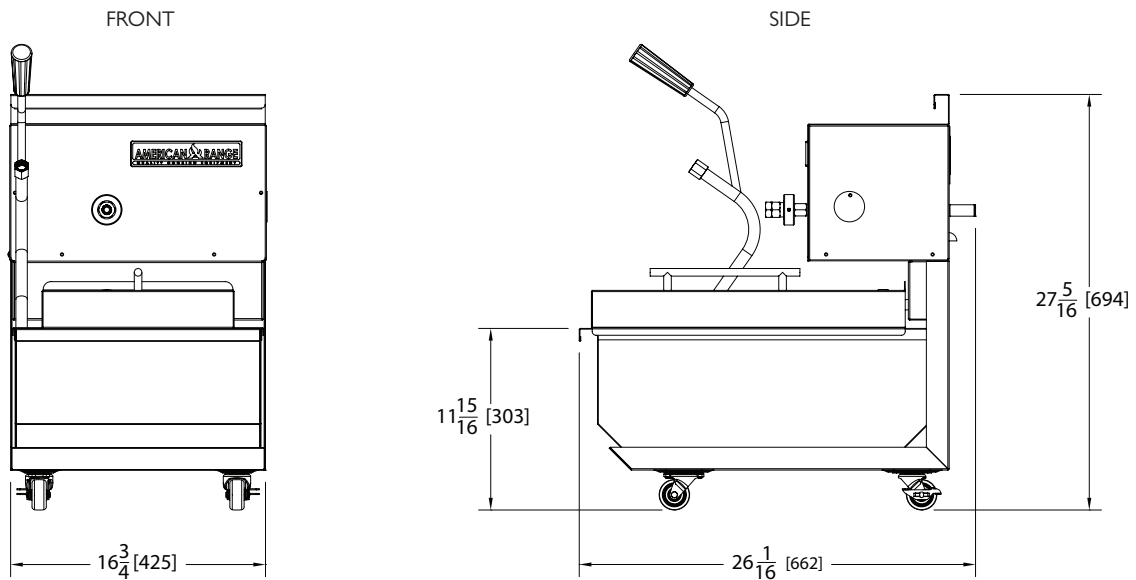

ARPFS - PORTABLE FRYER FILTRATION SYSTEM

Model	Description	Voltage	Shipping Weight	Lbs.	Kg.
ARPFS-35/50	Portable fryer filtration system	110V.		120	55
ARPFS-85	Portable fryer filtration system	110V.		140	64

STANDARD FEATURES

- A unitized Stainless Steel frame.
- Welded Stainless Steel pan with integrated handles for easy removal and cleaning.
- Rugged 1/3 HP UL and NSF approved motor and gear pump designed for long life.
- UL approved electrical controls.
- 1/2" diameter Teflon lined, nylon braided hoses with UL and NSF approvals.
- Unique nozzle design.
- Low profile to fit under drain valve tube.
- Uses industry standard SuperSorb CarbonPad® filter.
- One year limited warranty, parts and labor.

OPTIONAL FEATURES

- Filter pads (30 per case).

SPECIFICATIONS

Model ARPFS-35/50

Pan dimensions: 16" wide by 20" deep x 9" high. Total Pan Capacity: 1.63 cubic feet or 12.1 gallons of oil

Oil Capacity: 60 pounds of oil or 7.7 gallons. Shipping weight is 100 lbs.

Model ARPFS-85

Pan dimensions: 16" wide by 26" deep x 9" high. Total Pan Capacity: 2.1 cubic feet or 16.2 gallons of oil. Oil Capacity: 85 pounds of oil or 10.9 gallons.

Pump/Motor: ARPFS-35/50 & ARPFS-85

- Haight 5E Hot Oil Hub Mount Pump.
- Capacity: 4.6 GPM at 1750 RPM.
- 1/3 HP, Capacitor Start.
- Rotary Gear, positive displacement pump.
- 120 VAC, 6.2 AMP, 60 Hz.

Electrical Services: ARPFS-35/50 & ARPFS-85

- Standard 3 wire 120 VAC plug in cord.